

Specifications

Model NMSB III-b

Nasatka Barrier, Inc.
7702B Old Alexandria Ferry Rd.
Clinton, MD 20735
U.S.A.

Phone: (301) 868-0301

Fax: (301) 868-0524

Table of Contents

1. Warranty	page 3
2. Introduction	page 4
3. Standard Operating System.....	page 5-6
4. General Specifications	page 7-8
5. Specifications	page 9

WARRANTY

Each item of equipment in the Nasatka Maximum Security Barrier is warranted by Supplier for a period of one year, after delivery F.O.B. plant, unless otherwise specified by Supplier, from failure of operation in ordinary use and against defects due to faulty material or workmanship. Any defective equipment in the Nasatka Maximum Security Barrier shall be returned to the factory, at Supplier's option, for repair or replacement, and Supplier assumes no responsibility for service at any consumer site. Supplier is in no event responsible for any labor costs under the warranty. Subject to the above limitation, all service, parts, and replacements necessary to maintain the equipment as warranted shall be furnished by Supplier at no cost to consumer. Supplier shall not have any liability under these specifications, other than for repair or replacement as described above for equipment malfunction or equipment failure of any kind, caused for any reason, including, but not limited to unauthorized repairs, improper installation, installation not performed by Supplier personnel, nor by Supplier authorized personnel, modifications, misuse, accident, catastrophe, neglect, natural disaster, act of God or if at any time the power supplied to any part of the Nasatka Maximum Security Barrier falls short or exceeds the rate of tolerance for the equipment.

The exclusive remedy for breach of any warranty by Supplier shall be the repair or replacement at supplier's option, of any defects in the equipment. **IN NO EVENT SHALL THE SUPPLIER OF NASATKA MAXIMUM SECURITY BARRIER BE LIABLE FOR CONSEQUENTIAL OR SPECIAL DAMAGES OR ANY KIND OF DAMAGES TO ANYONE.** Except as provided herein, Supplier makes no warranties or representations to consumer or to anyone else and consumer hereby waives all liability against Supplier as well as any other person for the design, manufacture, sale, installation, and/or servicing of the Nasatka Maximum Security Barrier.

THE FOREGOING WARRANTIES ARE IN LIEU OF ALL OTHER WARRANTIES EXPRESS OR IMPLIED, INCLUDING THE IMPLIED WARRANTY OF MERCHANTABILITY AND FITNESS FOR A PARTICULAR PURPOSE. NO OTHER WARRANTIES EXIST.

Any modification or alteration by anyone other than NASATKA or NASATKA authorized personnel will render the NASATKA warranty herein as null and void.

INTRODUCTION

The Nasatka Maximum Security Vehicle Arrest Barrier plays a leading role in the vehicle access control industry. The patented surface mount design greatly simplifies barrier installation and eliminates *all* major site excavation. By utilizing the latest technology in the design of the proprietary hydraulic power unit and the microprocessor based electronic control system, the NMSB provides performance, reliability, safety and security unmatched in the industry.

Having been designed, manufactured, and approved to exceed 15,000-pound truck traveling at 50 mph, Nasatka will provide videocassette tapes to qualified parties who wish to witness the basic installation procedure and the stopping power of these devices.

Operating security has been maximized by eliminating the decisions required by the system attendant to the level that Nasatka can provide a totally automatic system, which requires no personnel to control vehicle access.

Each system is 100% factory tested and adjusted for normal installed operating conditions. The Barrier, Hydraulic Power Unit, and the Electronic Control are interconnected and run in all operating modes. This insures that each component part of the NMSB is functioning in accordance with the customer operating parameters and the quality assurance standards of Nasatka Barrier, Inc.

Nasatka's pre-procurement "check list" insures the proper system configuration and operation with the minimum expenditure of time and at the lowest possible cost.

In addition, our standard system documentation contains over 30 pages of detailed, step-by-step, information pertaining to all aspects of installation, start up, trouble shooting, and maintenance. Familiarity with vehicle access systems, hydraulics, or electronics is not required to properly install, operate, and maintain the NMSB!

DISCLAIMER:

All barriers systems should be carefully planned with safety as a paramount concern. The product is designed to control vehicle traffic. Nasatka Barrier is not a traffic safety-engineering firm and recommends that a system be review before installation. It is recommended that all forms of safety be used where possible, examples are proper lighting, written warnings sign, traffic lights, gate arm and audible.

STANDARD OPERATING SYSTEM

The following are the statements of operation for the standard NMSB barrier. If the functional requirements of the installation are different from the standard, Nasatka must be notified at the time of order and any additional cost for the required changes will be quoted as an addition to the standard price.

The four- (4) operating possibilities are:

- (1) The barrier is fully open (down).
- (2) The barrier is fully closed (secure).
- (3) The barrier is between fully open and fully closed and moving toward the closed position.
- (4) The barrier is between fully open and fully closed and moving toward the open position.

Results of all possible operator inputs, i.e., Emergency Close, Close, and Open, for the four (4) standard operating modes are described on the following pages.

Standard operating condition

(1) Barrier is fully open (down):

Operator input -

Result -

- | | |
|--------------------|--|
| A. Emergency Close | Barrier goes to secure position in approx. one (1) second. An alarm sounds continuously, until manual (key) reset of the system. |
| B. Close | Barrier goes to the fully secure position in standard operating time. |
| C. Open | No action. |

(2) Barrier is fully closed (secure):

Operator input -

Result -

A. Emergency close

Alarm sounds continuously, until manual (key) reset of the system.

B. Close

No action.

C. Open

Barrier goes to the fully open position in standard operating time.

(3) Barrier is between open and closed and moving toward secure position:

Operator input -

Result -

A. Emergency close

Barrier goes to secure position in approx. one (1) second. An alarm sounds continuously, until manual (key) reset of the system.

B. Close

Barrier continues toward the fully secure position in standard operating time.

C. Open

Barrier immediately reverses direction of travel and goes to the fully open position in standard operating time (slightly faster due to reduce travel).

(4) Barrier is between open and closed and moving toward open position:

Operator input -

Result -

A. Emergency close

Barrier immediately reverses direction of travel and goes to the secure position in approx. one (1) second. An alarm sounds continuously, until manual (key) reset of the system.

B. Close

Barrier immediately reverses direction of travel and goes to the fully secure position in standard operating time (slightly faster due to reduced travel).

C. Open

Barrier continues toward the fully open position in standard operating time.

Maximum Run Down Timer:

The CPU is equipped with an internal maximum run timer. This is used to prevent the motor from continuously running and causing damage to the system. The maximum run timer is set to 10 seconds. The timer is activated by an input from the system to lower the barrier. The timer is reset by the activation of the down button again.

Maximum Run Up Timer:

Up timer is about a three (3) second adjustable internal timer used to shut off the hydraulic motor and solenoid valve after the up button is pressed. The timer is activated whenever the up push button is pressed; the timer is used in place of a limit switch for the up cycle only.

Accumulator recharge:

Accumulator recharge: After the barrier is in the emergency mode and in the secure position, the hydraulic motor will remain engage for 10 seconds to recharge the accumulator. This will not affect the barrier position.

Barrier Start-Up

When first starting the barrier and the accumulator has not been charged, make sure that the accumulator valve is closed on the hydraulic unit. Press and hold the button in the direction that you want the barrier to move. (Note: If the button is pressed and the barrier does not move, this lack of action is due to the accumulator charging.) When the accumulator has reached the same pressure that the barrier needs to activate, then the barrier will begin to move. After the accumulator has been charged, the CPU in the control panel will maintain the accumulator. The CPU will charge the accumulator by recharging the system for two seconds for every ten cycles of barrier movement.

GENERAL SPECIFICATIONS

Purpose

The purpose of these specifications is to describe the Nasatka Maximum Security Barrier III-b.

Qualifications

Equipment names and model numbers included herein are those currently under production for or are utilized in the Nasatka Maximum Security Barrier III-b as of the writing of this specification, and are subject to change without notice.

Description of System

(See accompanying drawings for details.)

Make and Model: Nasatka Maximum Security Barrier III-b.

Road Width: Nominal 10 foot (3.05 meter) gate opening. Other widths available including configurations for bi-directional roads/access points.

Barrier Material: High impact steel having the following properties:

Yield Strength : 100 KSI
Tensile Strength : 110/130 KSI
Elongation (2 in.) : long 18 Trans 16

This material is produced in accordance with U.S. ASTM Specification T-1
Type B.

Barrier Height: In the fully "secure" position, the barrier height above the ground is 33 inches.

Barrier Dimensions: See accompanying drawing.

Response time: The barrier will erect to the fully "up" position in about five (5) seconds under normal operating conditions. E-up operations shall be about 2 seconds.

Cycling Time: The hydraulic pump system is sized to complete six (6) cycles (up/down) per minute.

Normal Activation: Electrically driven hydraulic pump operating at a pressure of 600 psi to a double-acting cylinder.

Position selection: The VBS shall be constructed such that the barrier remains in the position selected (open, closed) by the operator, i.e. no external hydraulic force shall be required to hold the VBS in the last position.

Oil Containment: The VBS shall meet Environmental Protection Agency standards set for oil containment. Oil containment units shall hold 1 gallons of oil for .5 gallon of oil in the reservoir.

Galvanized: All steel components of the barrier shall be hot dip galvanized.

Barrier Finish: Barrier surface exposed to traffic shall be painted with a red paint and a white reflective "STOP" on the impact side, for ease of visibility.

Operating Modes:

- A) Raise and lower barrier, normal conditions, operator command, momentary input.
- B) Raise and lower barrier, power failure condition, operator command, manual operation.
- C) Default to manual operation.
- D) Raise barrier to "up" position in emergency condition.

System Controller: Computer with relays and timers synchronized too properly operate a barrier.

Control Panel:

- A) Momentary switch to raise or lower the barrier.
- B) Audible alert, to activate whenever an emergency exists.
- C) Indicating lights for status of barrier position.

Power Source: 20 AMP, 208 VAC,
3-phase, 60 Hz mains power. Adaptable to 50 Hz power by component substitution.

Foundation Pad: The NMSB model III-b requires a reinforced concrete pad 14 ft (4.27m) by 10 ft (3.0m) by 16 inches deep (40.6cm).

Installed Weight: Approximately 7,500 lbs.

Optional Features: The following options are added to enhance the performance and operation of the NMSB:

- * Master control panel.
- * Remote control panel.
- * Indicator lights for barrier status.
- * Loop Detectors (safety).
- * Traffic lights (red & yellow).
- * Gate arm.
- * Loop Detectors (access control).
- * Cardreader
- * Hydraulic heat.
- * Slab heater
- * E-up operation

SPECIFICATIONS

MODEL: NMSB III-b

CRASH TESTED: 15,000 lbs at 50 mph (K12 L3)

WEIGHT: 7,500 lbs.

SIZE: Length - 13'4", Width - 79" (for standard 10' barrier) Height - 33"

VOLTAGE: The NMSB is supplied to operate from standard 3-phase line voltage between 208-220/460 volts. Controls operate on 120vac, master panel operate on 24vac

FREQUENCY: 60 HZ, 2 HP Motor

FULL LOAD CURRENT: The full load current depends on the actual line voltage and frequency that the barrier is operated from. The following are two examples:

- 5.6 AMP @ 208 V, 60 HZ
- 2.7 AMP @ 460 V, 60 HZ

OPERATOR CONTROLS: Emergency Up, Up, and Down momentary push buttons.

HYDRAULIC FLUID: Capacity - 5-gallon nominal.

Type -U.S.P.P petroleum base.

Recommended Brand - Dexron III Transmission Fluid.

EMERGENCY HYDRAULIC RESERVE: The system automatically maintains approximately 2 half-cycles of hydraulic potential, which is manually made available only during power or E-up conditions

CYCLE TIME: Nominal 2 cycle (raise or lower) time is 5 seconds for normal operation. E-up operation shall be about 2 second

MANUAL OPERATION: Raise and lower the barrier by a single person, without the aid of electric or hydraulic power. Cycle time~3 seconds or less.

HYDRAULIC PRESSURE: (factory setting)

Pump Output - 1400-PSI relief valve setting

Barrier Requirements - 600 PSI

OPERATING TEMPERATURE: -10° to 120° Fahrenheit.

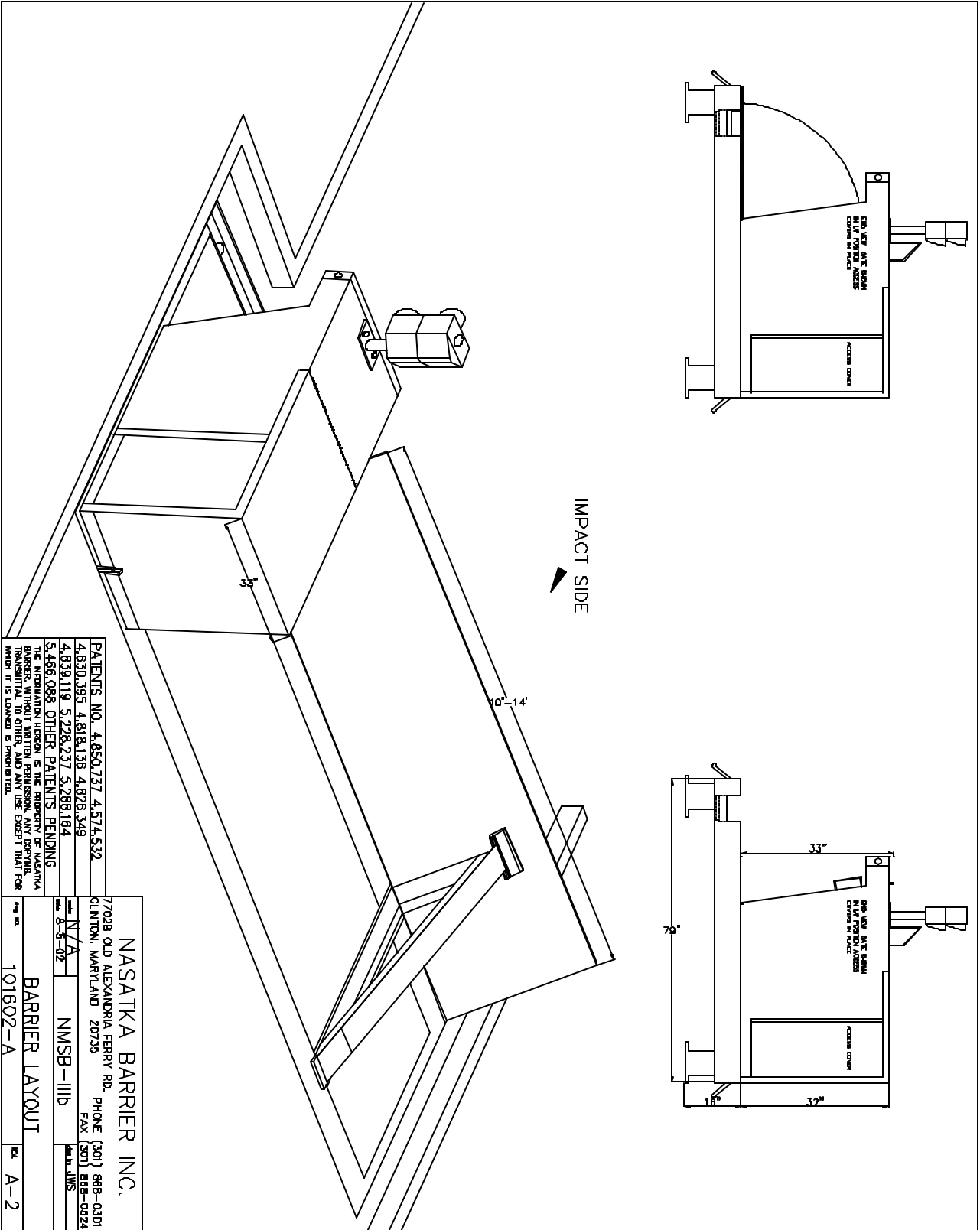

PATENTS NO. 4,850,737 4,574,532
 4,830,395 4,818,138 4,828,349
 4,839,119 5,228,237 5,288,184
 5,488,088 OTHER PATENTS PENDING
 THE INFORMATION HEREON IS THE PROPERTY OF NASATKA
 INC. AND IS NOT TO BE REPRODUCED OR
 TRANSMITTED IN ANY FORM OR BY ANY MEANS
 WITHOUT THE WRITTEN PERMISSION OF NASATKA
 INC. IF IT VIOLATES FEDERAL LAWS.

NASATKA BARRIER INC.
 7702B OLD ALEXANDRIA FERRY RD.
 CLINTON, MARYLAND 20725
 PHONE (301) 888-0301
 FAX (301) 888-0924
 WWW.N/A
 E-MAIL NMSB-III@NASATKA.COM
BARRIER LAYOUT
 101602-A
 REV. A-2

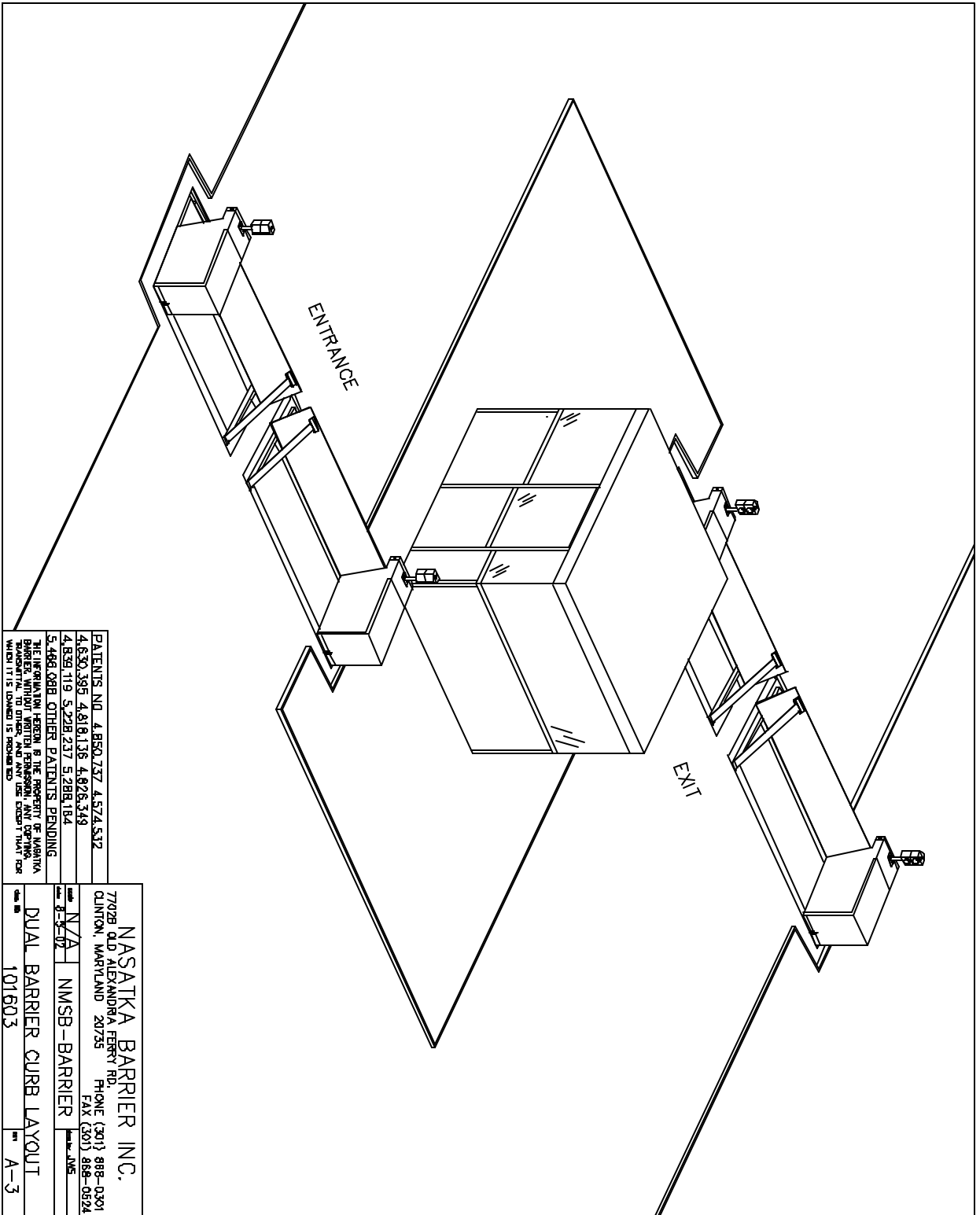

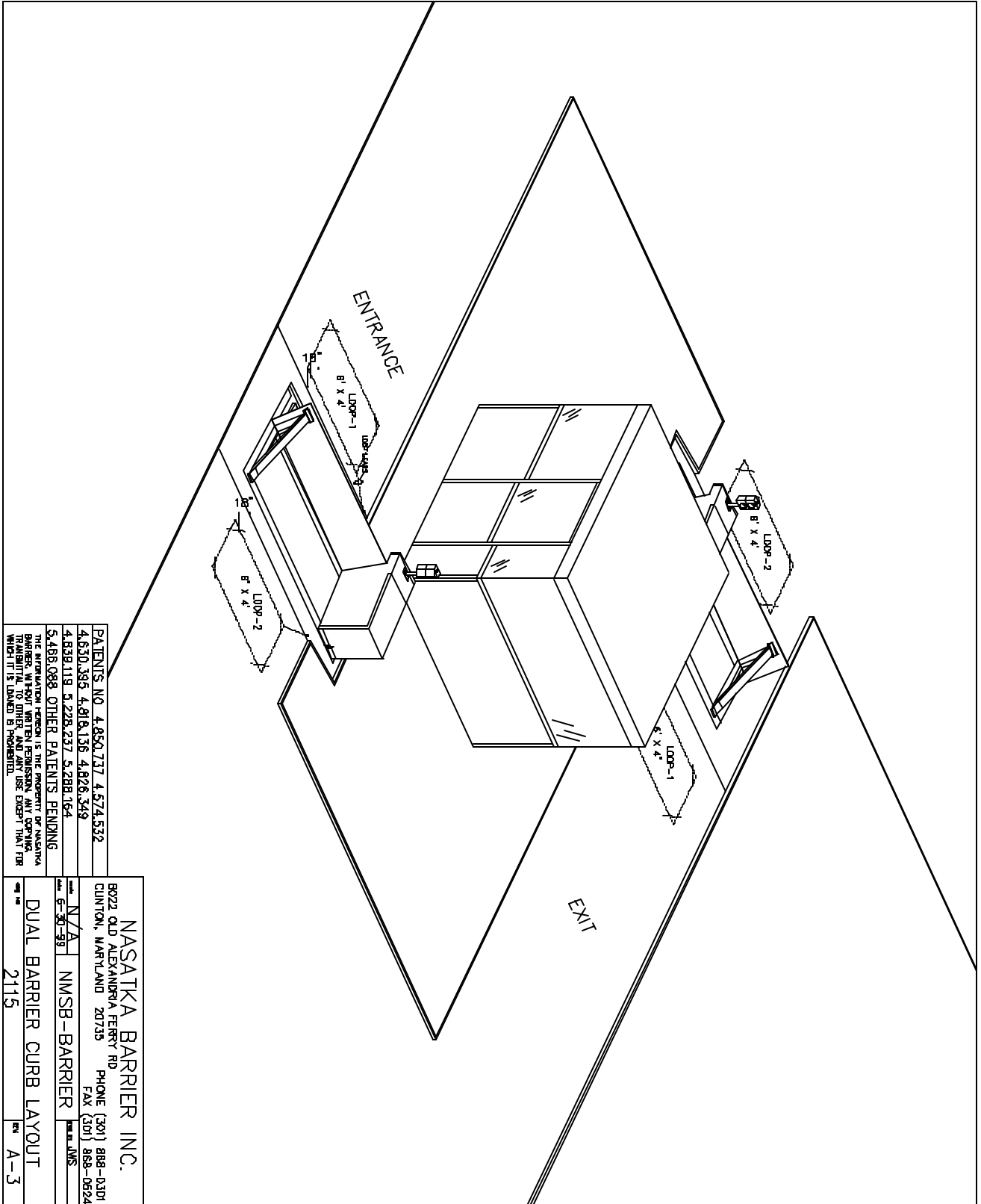

PATENTS NO. 4,850,737 4,524,532
 4,630,366 4,618,136 4,626,349
 4,829,119 5,228,237 5,288,164
 5,458,088 OTHER PATENTS PENDING

THE INFORMATION HEREON IS THE PROPERTY OF NASATKA BARRIER. WITHOUT WRITTEN PERMISSION, ANY COPYING, REPRODUCTION, OR OTHER UNLAWFUL USE EXCEPT THAT FOR WHICH IT IS ISSUED IS PROHIBITED.

NASATKA BARRIER INC.
 8022 OLD ALEXANDRIA FERRY RD
 CLINTON, MARYLAND 20735
 PHONE (301) 888-0301
 FAX (301) 888-0624

DATE: 6-30-99
 N/A
 NMSB-BARRIER
 DRAWN BY: JMS

DUAL BARRIER CURB LAYOUT
 2115
 REV: A-3

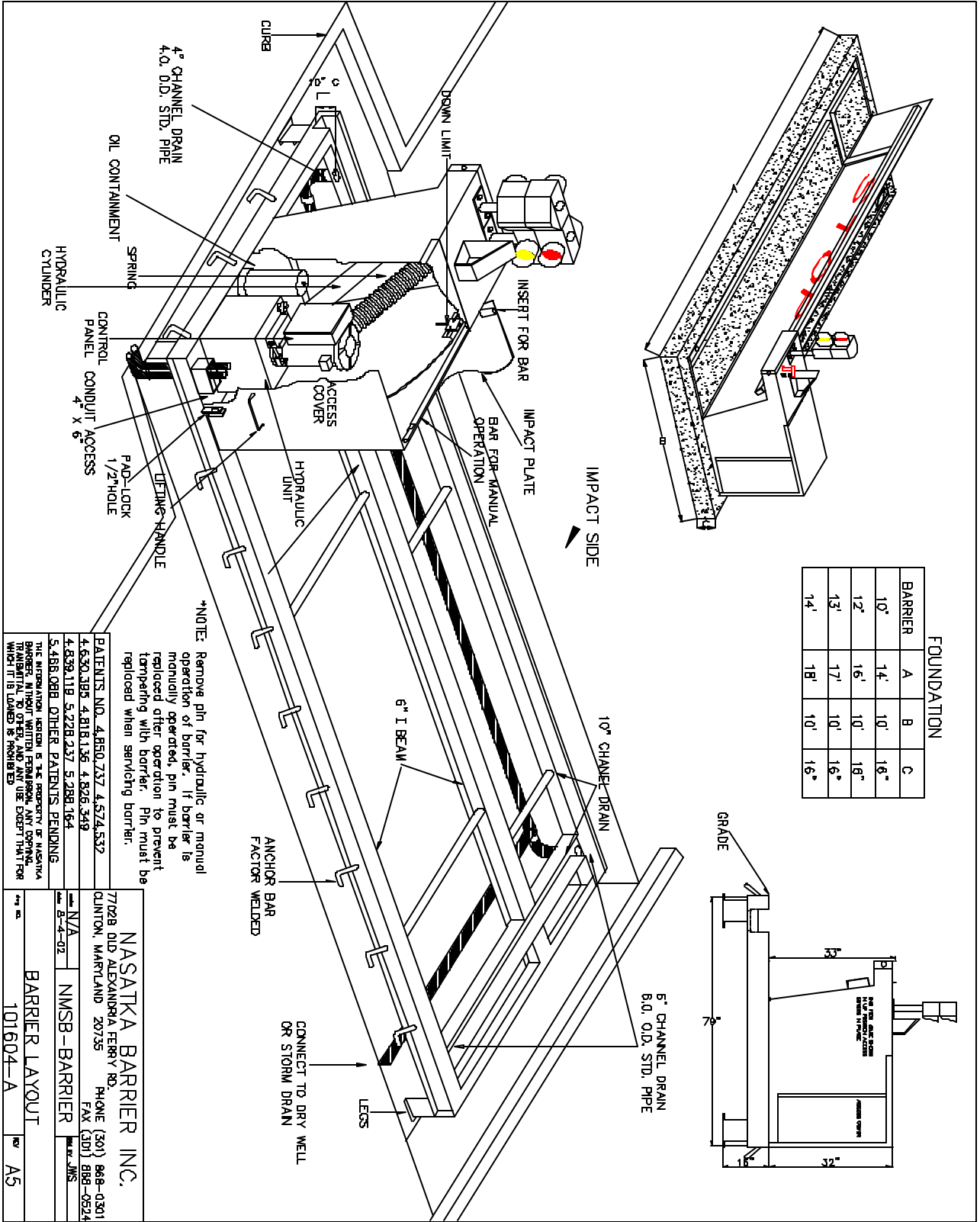

*NOTE: Remove pin for hydraulic or manual operation of barrier. If barrier is manually operated, pin must be replaced after operation to prevent tampering with barrier. Pin must be replaced when servicing barrier.

NASATKA BARRIER INC.
 7702B OLD ALEXANDRIA FERRY RD.
 CLINTON, MARYLAND 20735
 PHONE (301) 968-0301
 FAX (301) 988-0524

DATE: 8-2-02
 DRAWN BY: N/A
 CHECKED BY: N/A
 PROJECT: MMSB-BARRIER

101604-A A5

DIRECTION OF IMPACT
PLAN VIEW

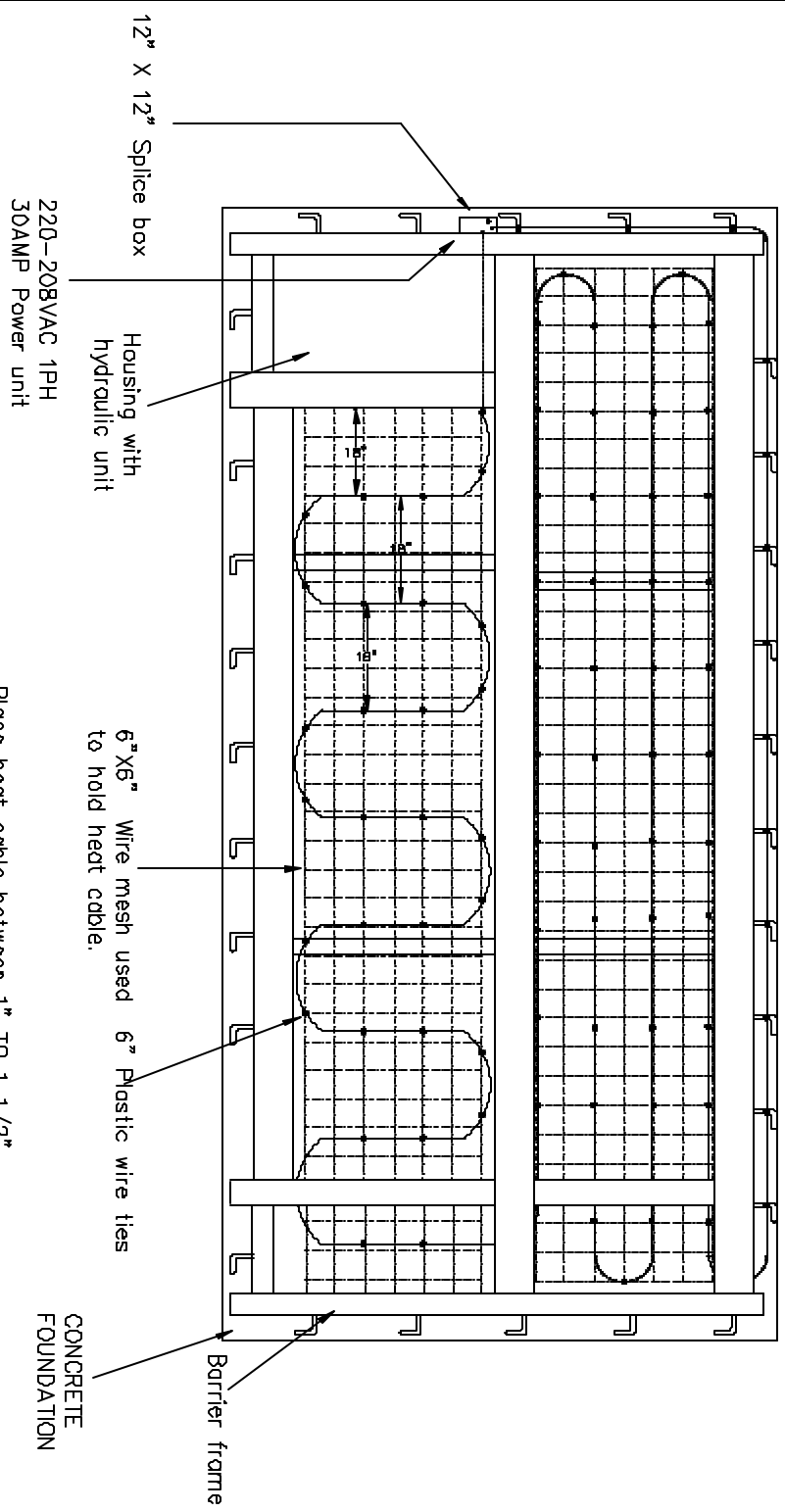

Place heat cable between 1" TO 1 1/2" below finish grade of concrete.

NOTE1: Power feed to the heat cable is independent of power to the hydraulic and controls.

NOTE2: Left handed unit shown right handed is mirror image of left handed unit.

PATENTS NO. 4,880,737 4,574,532		7702B OLD ALEXANDRIA FERRY RD.	
4,630,395 4,818,138 4,826,349		CLINTON, MARYLAND 20735	
4,838,118 5,228,237 5,288,184		PHONE (301) 888-0301	
5,466,098 OTHER PATENTS PENDING		FAX (301) 888-0924	
THIS DRAWING IS THE PROPERTY OF NASATKA BARRIER INC. IT IS LOANED TO YOU AND NOT TO BE REPRODUCED OR COPIED WITHOUT WRITTEN PERMISSION. ANY OTHER USE WITHOUT WRITTEN PERMISSION IS PROHIBITED.			
HEAT CABLE LAYOUT		NASATKA BARRIER INC.	
TYPICAL LAYOUT		CLINTON, MARYLAND 20735	
REV B		PHONE (301) 888-0301	
		FAX (301) 888-0924	
		DATE 10-14-99	
		BY JMS	