

1 2 3 4 5

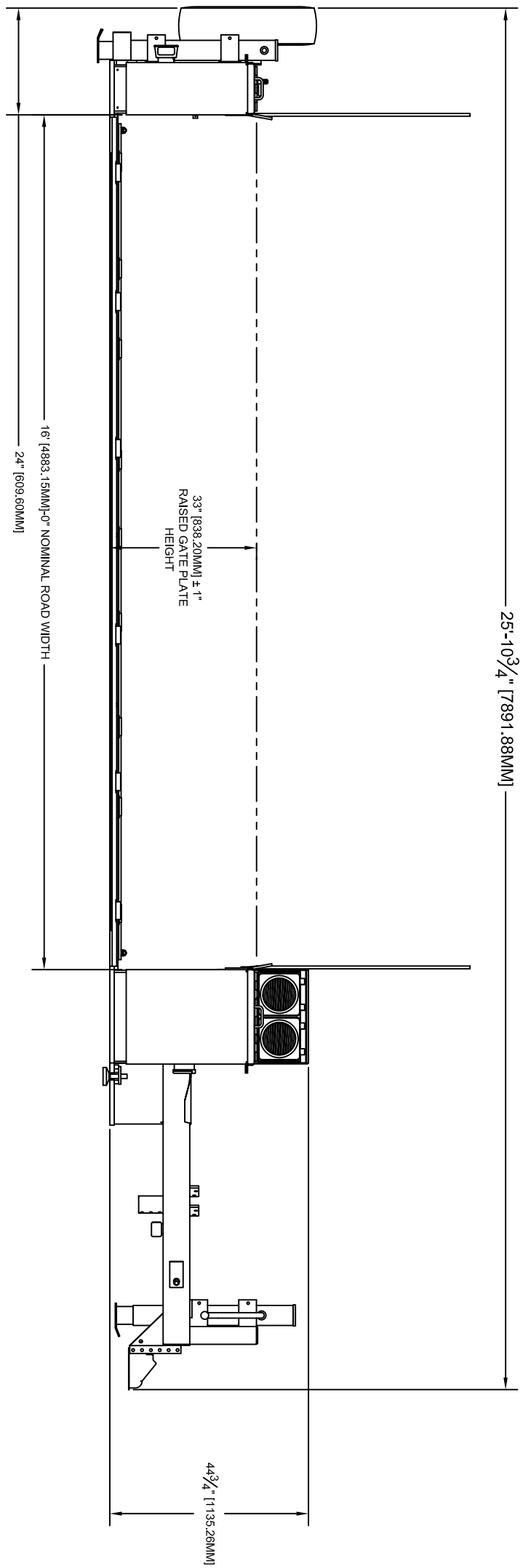
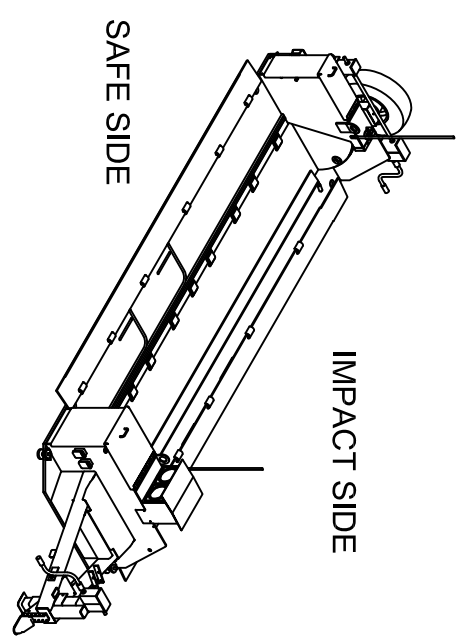
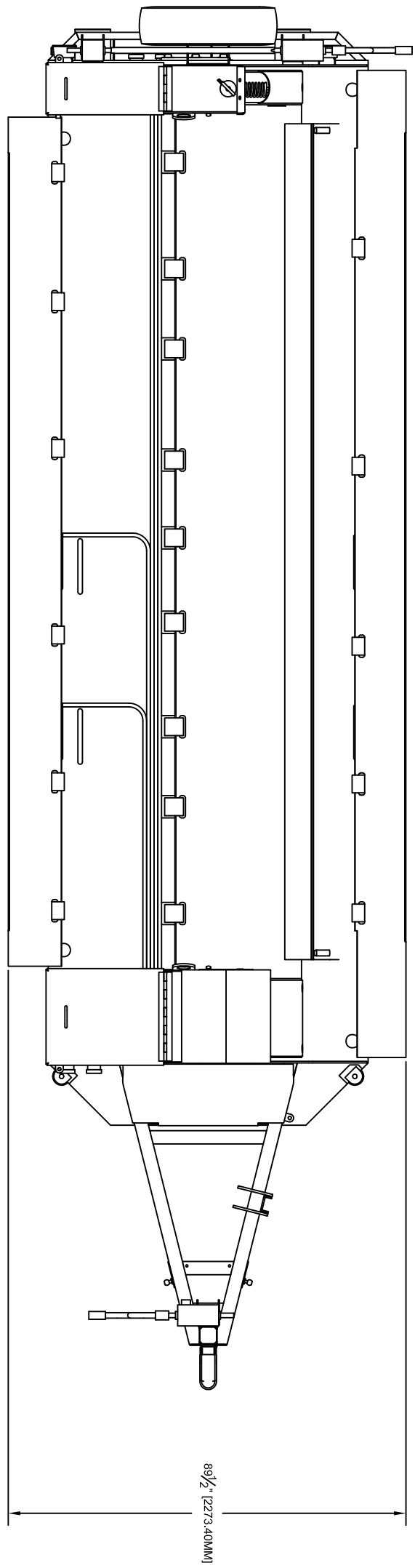

Sheet: SB-1	DESCRIPTION:  NMSB XVI MOBILE BARRIER  16 FT CLEAR OPENING			REV.	DATE	DESCRIPTION	THIS DOCUMENT CONTAINS INFORMATION DEEMED CONFIDENTIAL AND PROPRIETARY TO NASATKA BARRIER, INC. AND MAY NOT BE REPRODUCED IN WHOLE OR IN PART WITHOUT THE EXPRESS WRITTEN PERMISSION OF NASATKA BARRIER, INC. FURTHER, NO USE OF THIS DOCUMENT OR THE INFORMATION CONTAINED HEREIN MAY BE MADE WITHOUT FIRST SECURING THE PRIOR WRITTEN APPROVAL OF NASATKA BARRIER, INC.	
	Part: NO.	###		DRAWN BY:	EMS	CHK BY:		
Sec: WS				SCALE:	NTS	DATE:	11/16/2012	